



US009366052B1

(12) **United States Patent**  
**Warner et al.**

(10) **Patent No.:** **US 9,366,052 B1**  
(45) **Date of Patent:** **Jun. 14, 2016**

(54) **STRUCTURAL SUPPORT APPARATUS AND METHOD OF INSTALLATION THEREOF**

(71) Applicant: **Solid Structures**, Spokane, WA (US)

(72) Inventors: **James Lee Warner**, Colbert, WA (US);  
**Jensen James Lewis**, Colbert, WA (US)

(73) Assignee: **Solid Structures**, Spokane, WA (US)

(\*) Notice: Subject to any disclaimer, the term of this patent is extended or adjusted under 35 U.S.C. 154(b) by 0 days.

(21) Appl. No.: **14/610,825**

(22) Filed: **Jan. 30, 2015**

(51) **Int. Cl.**  
**E04H 12/22** (2006.01)

(52) **U.S. Cl.**  
CPC ..... **E04H 12/2284** (2013.01); **E04H 12/2253** (2013.01); **E04H 12/2261** (2013.01); **E04H 12/2269** (2013.01)

(58) **Field of Classification Search**  
CPC ..... E04H 12/2269; E04H 12/2261; E04H 12/2284; E04H 12/2253; E04H 12/22  
See application file for complete search history.

(56) **References Cited**

U.S. PATENT DOCUMENTS

4,199,908 A \* 4/1980 Teeters ..... E04H 12/2284  
248/357  
4,614,070 A \* 9/1986 Idland ..... E04H 12/2253  
52/295

4,924,648 A \* 5/1990 Gilb ..... E04B 1/41  
52/295  
5,375,384 A \* 12/1994 Wolfson ..... E04B 1/0007  
52/295  
5,561,950 A \* 10/1996 Collins ..... E02D 27/32  
248/354.3  
5,666,774 A \* 9/1997 Commins ..... E04H 12/2253  
248/188.4  
5,697,190 A \* 12/1997 Scribner ..... E04H 12/2223  
248/530  
6,513,290 B2 \* 2/2003 Leek ..... E04B 1/2604  
403/232.1

\* cited by examiner

Primary Examiner — Andrew J Triggs

(74) Attorney, Agent, or Firm — Lee & Hayes, PLLC

(57) **ABSTRACT**

An apparatus includes a first strap including an upper end and a lower end. A second strap is disposed adjacent to the first strap and includes an upper end and a lower end. The upper and lower ends of the second strap correspond in position with respect to the upper and lower ends of the first strap. A base portion connects the first and second straps between the respective lower ends of the first and second straps. A height adjustment system includes at least one bar disposed adjacent to at least one of the first and second straps, and a lift assist component that engages with the bar. In an orientation where the first and second straps extend vertically with respect to a horizontal plane, a distance between the horizontal plane and the respective upper ends of the first and second straps is adjustable via engagement between the lift assist component and the bar.

**21 Claims, 8 Drawing Sheets**

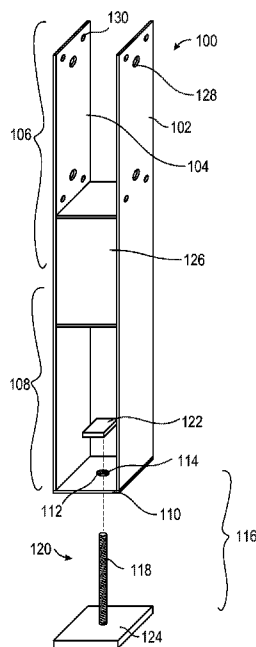

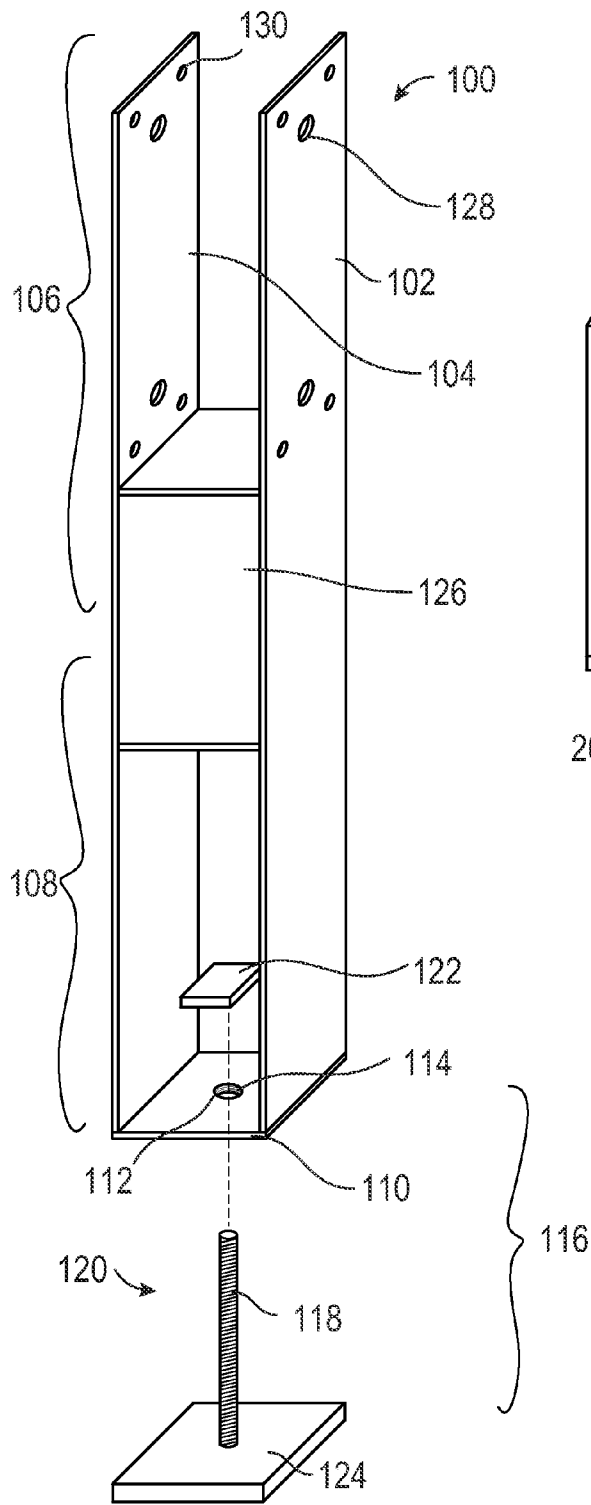

FIG. 1

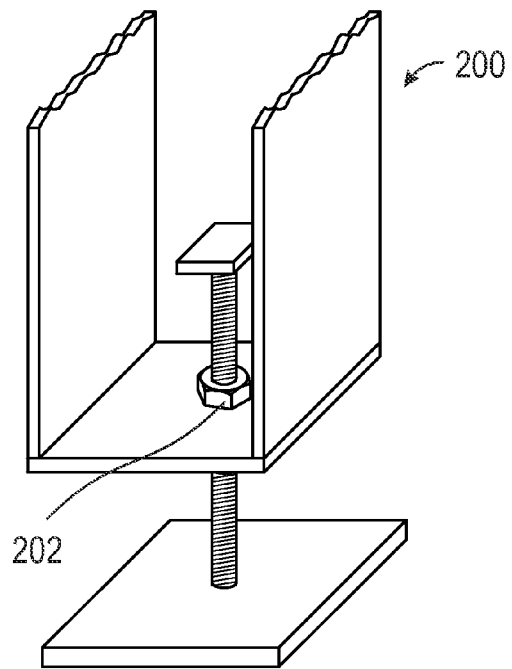

FIG. 2

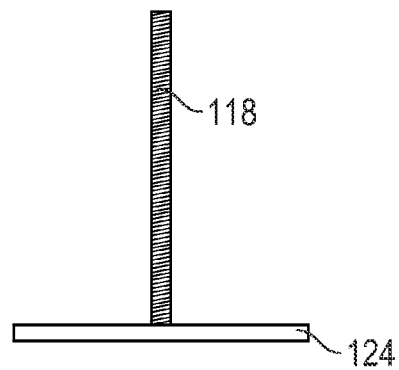

FIG. 3

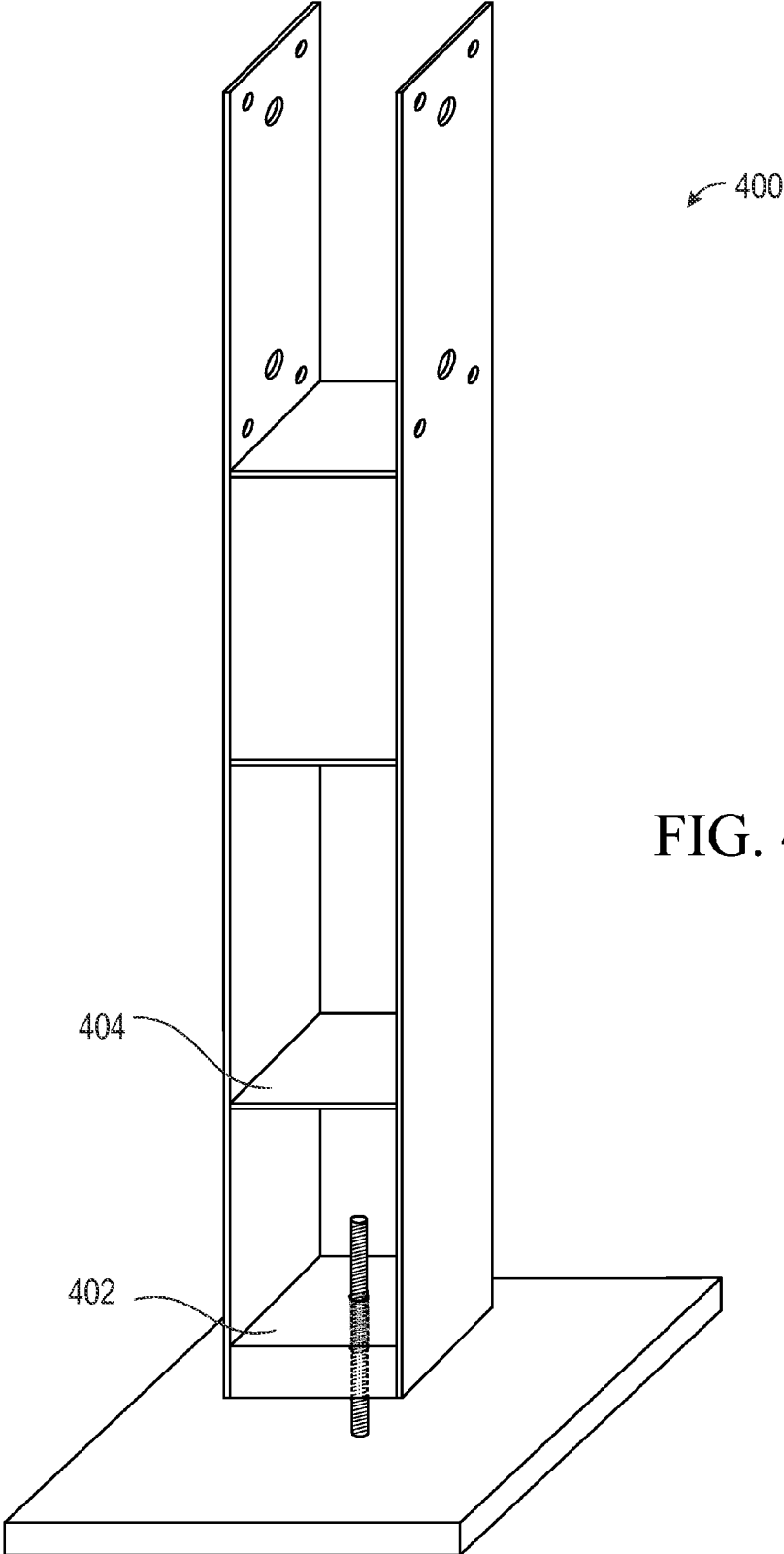

FIG. 4

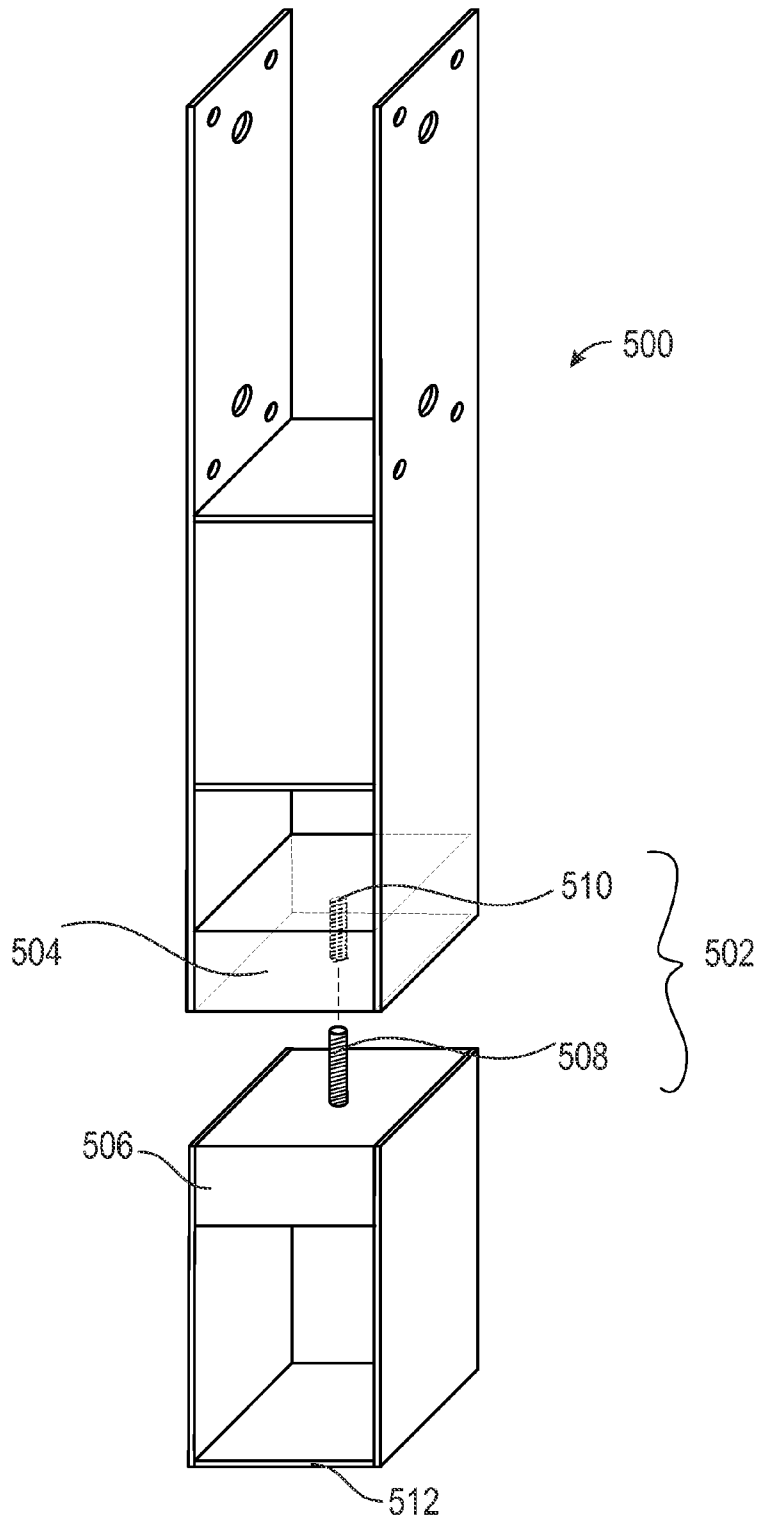

FIG. 5

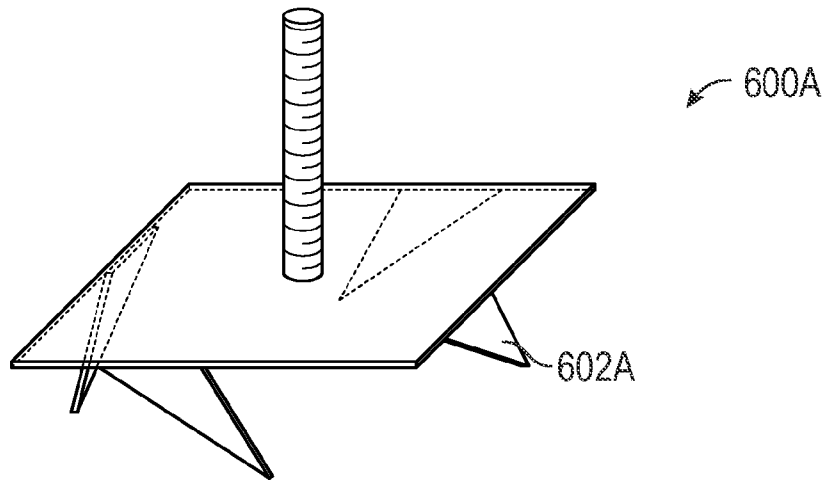

FIG. 6A

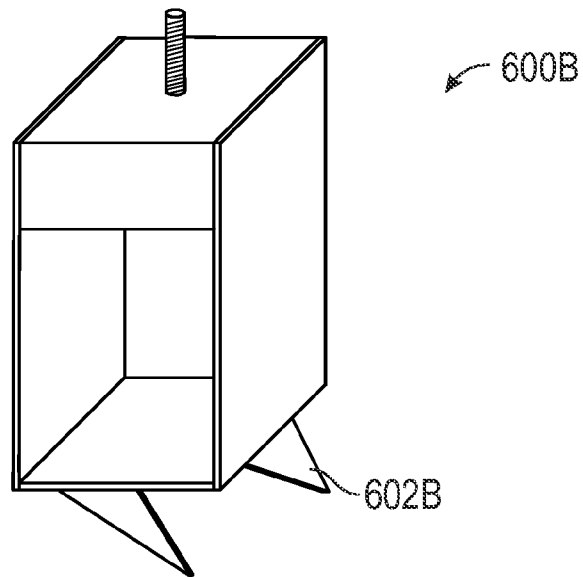

FIG. 6B

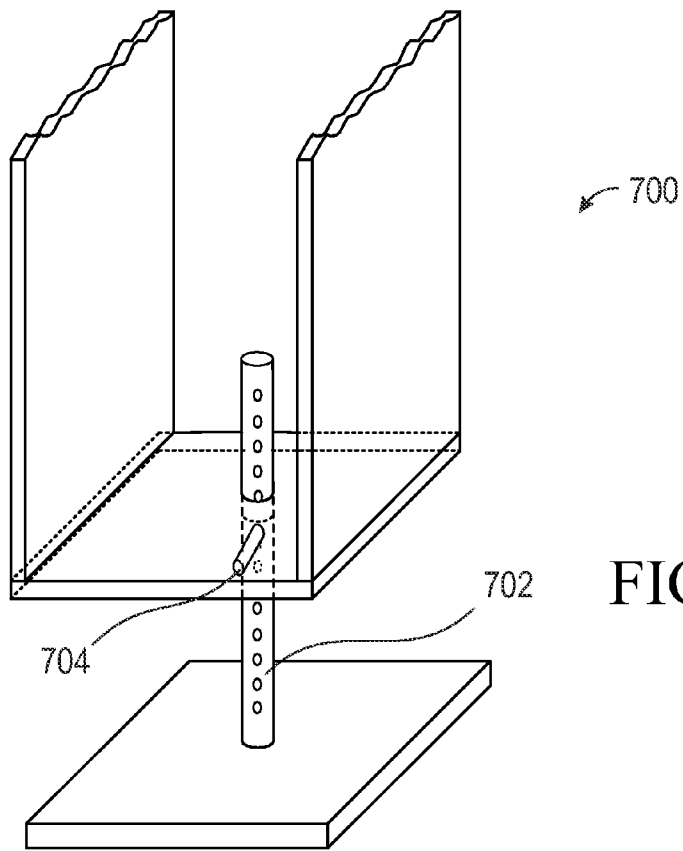

FIG. 7A

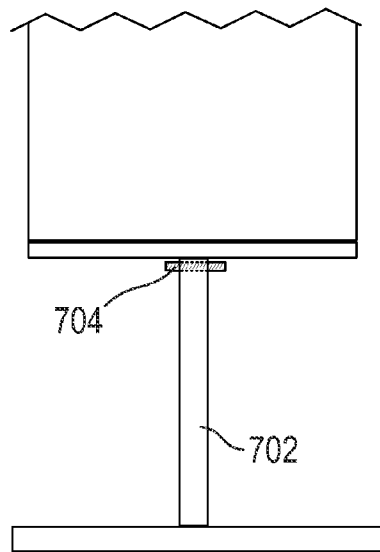

FIG. 7B

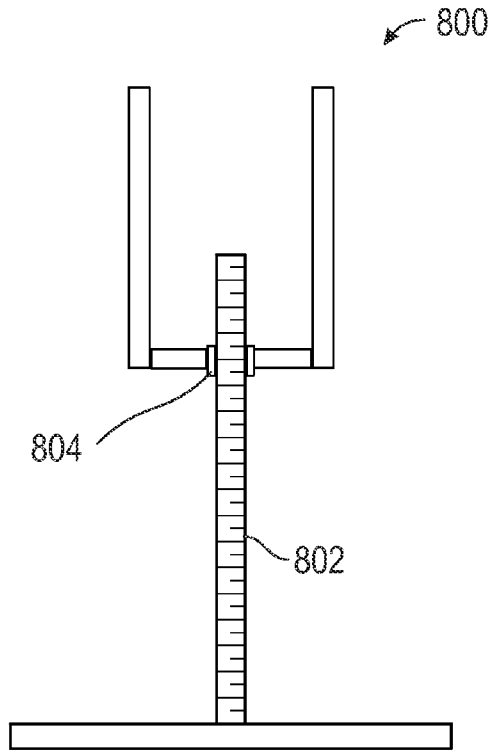

FIG. 8

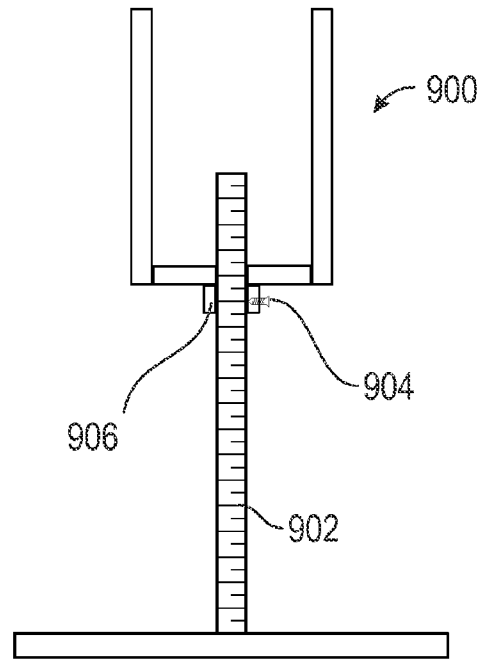

FIG. 9

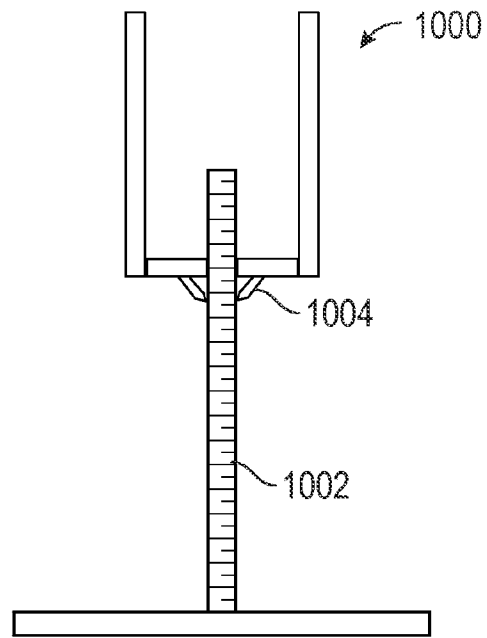

FIG. 10

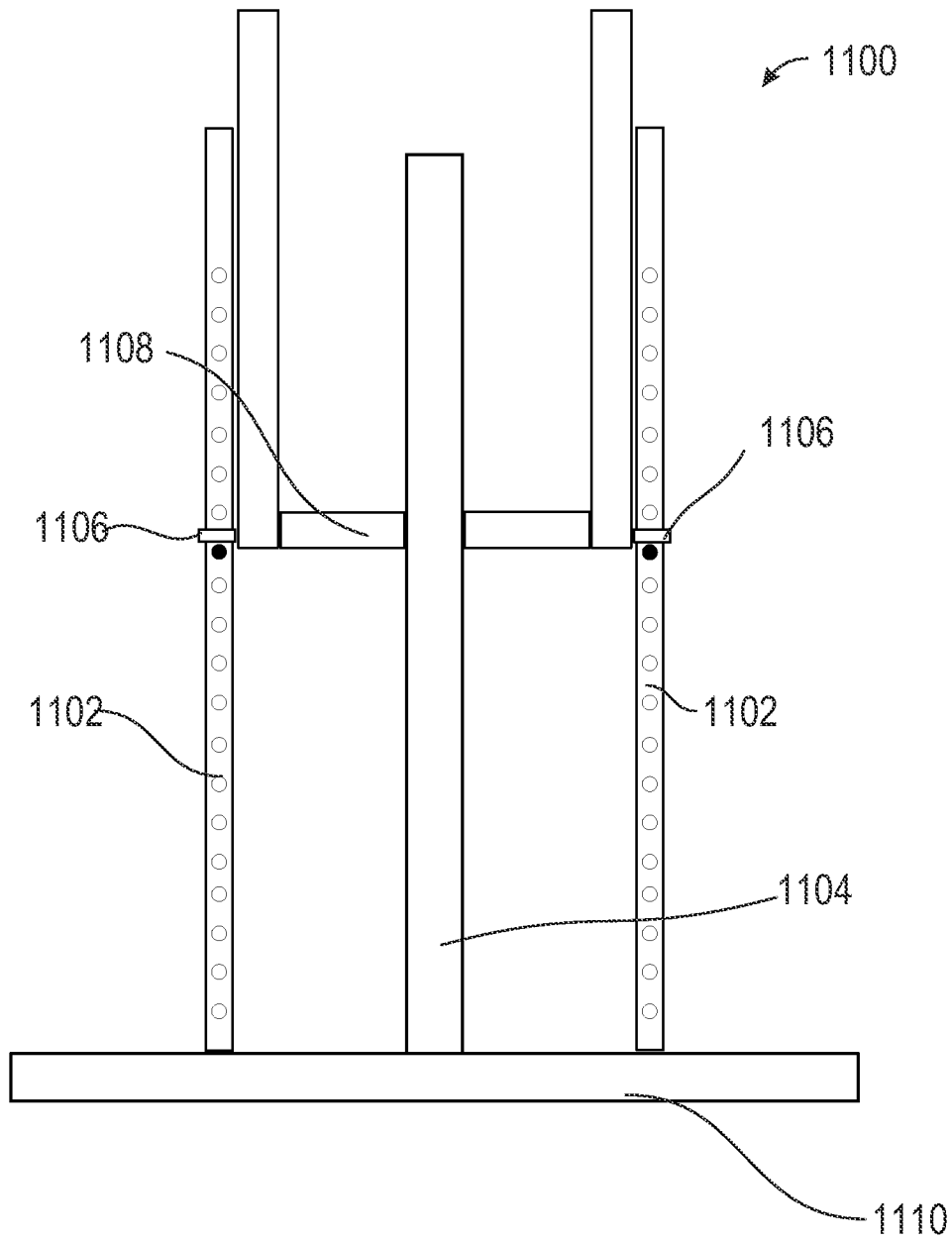

FIG. 11



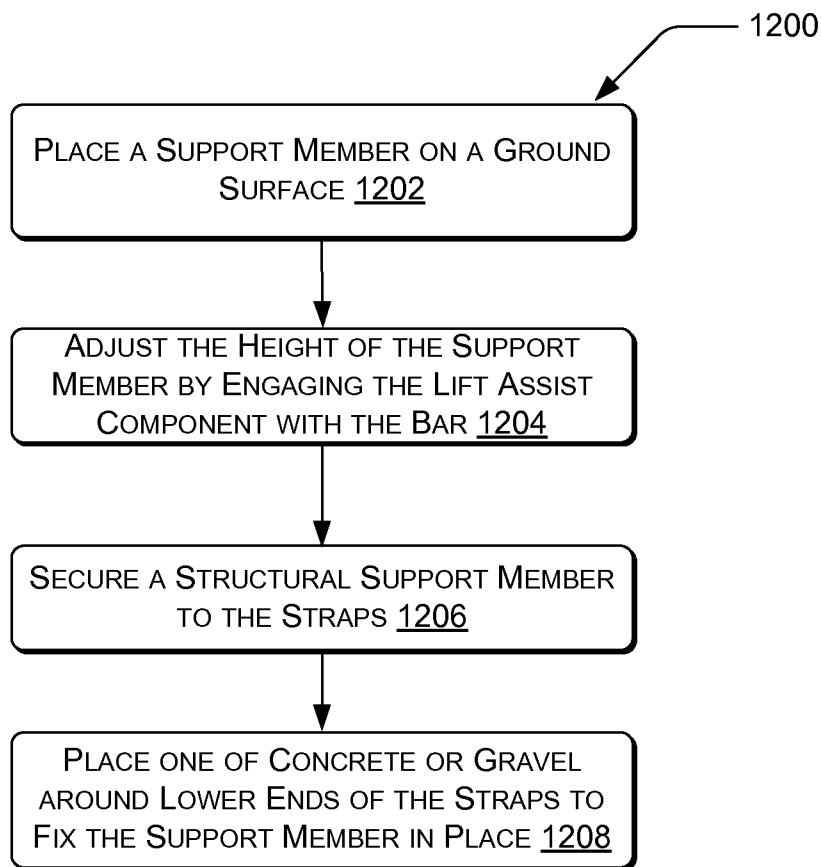

FIG. 12

1

## STRUCTURAL SUPPORT APPARATUS AND METHOD OF INSTALLATION THEREOF

### BACKGROUND

A pole building or a post frame building is a building structure, made in a quick and simplified manner, which may be of multiple varieties, including barns, sheds, shops, homes, etc. Generally, the basic structure of a pole building included a framework of columns on which walls and/or an overhead shelter may be built. Traditionally, the frameworks have been formed by partially burying large poles or posts in the ground so as to make upright columns that can be framed or otherwise built up. In more recent times, in lieu of simply burying the poles, the poles or posts have been fastened to a foundation or support means, such as a concrete pad. While burying the poles provides good lateral stability, the direct exposure to soil or other stabilizing materials, such as concrete or gravel, may cause rot and decay in poles, particularly when the pole is made of wood. Therefore, instead of wood, some pole buildings implement poles cast entirely in concrete.

When constructing a pole building, one challenge faced by the builders is to ensure that the height of the poles is accurate according to the necessary grade. Further, in order to ensure stability and safety, the poles are generally buried to a predetermined depth to help prevent the structure from merely being blown over or ripped from the ground. Despite excavation capabilities, these factors present a challenge due to the differences in the natural land surface and content from place to place, even in a single space of land for the same building. Generally, a height adjustment is done by repeatedly performing a process to check the height until the height is correct. The process may include inserting a pole into an excavated hole, checking the height, and removing the pole from the hole to add or remove material under the pole. Thus, current methods of height adjustment are time-consuming and difficult.

### BRIEF DESCRIPTION OF THE DRAWINGS

The Detailed Description is set forth with reference to the accompanying figures. In the figures, the left-most digit(s) of a reference number identifies the figure in which the reference number first appears. The use of the same reference numbers in different figures indicates similar or identical items.

FIG. 1 illustrates an exploded isometric view of a structural support apparatus.

FIG. 2 illustrates an assembled isometric view of the lower portion of an alternative embodiment of a structural support apparatus.

FIG. 3 illustrates a side view of an example base portion.

FIG. 4 illustrates an isometric view of another alternative embodiment of a structural support apparatus.

FIG. 5 illustrates an isometric view of yet another alternative embodiment of a structural support apparatus.

FIG. 6A illustrates an isometric view an example embodiment of a ground plate.

FIG. 6B illustrates an isometric view an example embodiment of a base portion.

FIG. 7A illustrates an isometric view of the lower portion of another alternative embodiment of a structural support apparatus.

FIG. 7B illustrates a side view of the apparatus shown in FIG. 7A.

FIG. 8 illustrates a side view of another example embodiment of the lower portion of a structural support apparatus.

2

FIG. 9 illustrates a side view of yet another example embodiment of the lower portion of a structural support apparatus.

FIG. 10 illustrates a side view of a different example embodiment of the lower portion of a structural support apparatus.

FIG. 11 illustrates a side view of an example embodiment of the lower portion of a structural support apparatus where the bar is outside of the straps.

FIG. 12 illustrates a flowchart of a method of installing the structural support apparatus.

### DETAILED DESCRIPTION

#### Overview

This disclosure is directed to a structural support apparatus, which is well-suited for many uses, but particularly for pole buildings (also known as a post frame building). The disclosure is further directed to method for installing a structural support apparatus having the features discussed herein. A pole building is a building structure, made in a quick and simplified manner, which may be of multiple varieties, including barns, sheds, shops, homes, etc. Generally, the basic structure of a pole building included a framework of columns on which walls and/or an overhead shelter may be built. Traditionally, the frameworks have been formed by partially burying large poles or posts in the ground so as to make upright columns that can be framed or otherwise built up. In more recent times, in lieu of simply burying the poles, the poles or posts have been fastened to a foundation or support means, such as a concrete pad. While burying the poles provides good lateral stability, the direct exposure to soil or other stabilizing materials, such as concrete or gravel, may cause rot and decay in poles, particularly when the pole is made of wood. Therefore, instead of wood, some pole buildings implement poles cast entirely in concrete. However, this method is cumbersome and costly due, in large part, to the heavy weight of the pre-cast concrete pole.

As explained herein, a structural support apparatus according to the features depicted and described simplifies the process of adjusting the height of the support member and thus, the column thereon as well. Further, the structural support apparatus described herein improves the ease of construction and minimizes costs. Moreover, features such as the height adjustment system of the various embodiments of the structural support apparatus of this application maintain and improve the structural integrity of the pole building.

In an example, a structural support apparatus may include a height adjustment system that quickly allows a user to adjust the height without needing to remove the pole repeatedly to add or remove matter beneath the pole.

Accordingly, the structural support apparatus described herein may accurately and effectively assist a user in quickly constructing a pole building. In the following paragraphs various embodiments of a structural support apparatus including a height adjustment system are described.

#### Illustrative Embodiments of a Structural Support Apparatus

FIG. 1 illustrates an embodiment of a structural support apparatus **100**. The structural support apparatus **100** may include a first strap **102** and a second strap **104** facing the first strap **102**. Each of the first and second straps **102**, **104** may be visually divided for the purpose of the discussion in the specification (or literally divided, as in FIG. 5) into an upper portion **106**, which is roughly the top half of the first and second straps **102**, **104**, and a lower portion **108**, which is roughly the bottom half of the first and second straps **102**,

104. The first and second straps 102, 104 may be elongated, thin plates to which a column may be attached upon installation of the apparatus 100.

It is noted that straps, such as the first and second straps 102, 104 of this application, as well as the other elements of the structural support apparatuses described herein may be made of a material resistant to deterioration when buried in soil or surrounded by another material, such as concrete, for example. Thus, the structural support apparatuses described herein may be made of a metal, such as steel, for example, or other suitable materials.

The first and second straps 102, 104 may be secured close to each other by one or more connection members. Some of the connection members may include a base portion 110, a capped tube ("support column rest") 126, and a stiffener plate (shown as element 404 in FIG. 4). The base portion 110 may be located at a lowermost end of the structural support apparatus 100, and may anchor the first strap 102 to the second strap 104. The base portion 110 may have a hole 112. Other embodiments may not have the hole 112, as seen in FIG. 5, for example. As depicted in FIG. 1, the hole 112 may also have a threaded surface 114.

Furthermore, the structural support apparatus 100 may include a height adjustment system 116. In some embodiments, the height adjustment system 116 may include a bar 118, a lift assist component 120, an obstruction 122, and a ground plate 124. In the embodiment of FIG. 1, the bar 118 may be connected to the ground plate 124 and may pass through the hole 112 of the base portion 110. The height adjustment system 116 may further include the lift assist component 120, which may be the threaded surface of the bar 118. Threaded surface 114 of the hole in the base plate 110 may be sized to accommodate the threaded surface on the bar 118. A first end of the bar 118 may be attached to the ground plate 124. Accordingly, with these components, the height of the structural support apparatus 100 may be easily adjusted by rotating the upper portion 106 of the straps 102, 104 about the axis of the bar 118 so that the straps 102, 104 are raised or lowered as desired, by engaging the threaded surface 114 with the bar 118.

While not a necessity, a second end of the bar 118 may be attached to an obstruction 122, which may help prevent the bar 118 from threading completely out of the base portion 110.

The structural support apparatus 100 may also include another connection member that is a support column rest 126. The support column rest 126 may securely anchor the first strap 102 to the second strap 104. It is noted that the support column rest 126 is depicted as extending along the first and second straps 102, 104 and is thus longer than the base portion 110, however, the base portion 110 is not limited to the plate-like shape shown in FIG. 1.

Moreover, the structural support apparatus 100 may include holes 128 and 130 in a corresponding pattern in the first and second straps 102, 104. In particular, the patterned holes 128, 130 may be located in the respective upper portions of the first and second straps 102, 104 in such a position so as to create a specific moment, which is beneficial for the integrity of the structure. For example, in an embodiment (not drawn to scale in the Figures), there may be two 1/4 inch holes, located 3/4 inch below the top of the straps and 3/4 inches inward from each side, respectively. Another pair of 1/4 inch holes that may be found 3/4 inches in from a side, may also be located 23/4 inches down from a top of the straps. Additionally, a pair of 3/4 inch holes may be located in the center line of the straps, at 3 and 21 inches, respectively.

With respect to the portion of the structural support apparatus 200 shown in FIG. 2, although the height adjustment system 116 (of FIG. 1), may be similar to the components height adjustment system in FIG. 2, the structural support apparatus 200 may include a threaded nut 202, instead of the threaded surface 114 on the hole 112 itself, as in FIG. 1. Thus, similar to FIG. 1, the height of the structural support apparatus 100 may be easily adjusted by rotating the upper portion 106 of the straps 102, 104. Additionally, despite the presence of the obstruction 122 shown in FIGS. 1 and 2, it is contemplated that the bar of the structural support apparatus may be used and/or built without an obstruction 122, as seen in FIGS. 4-11.

FIG. 3 merely shows the side view profile of the bar 118 attached to the ground plate 124. Inasmuch as FIG. 3 shows a side profile, it is noted that the ground plate 124 may be one of multiple shapes including circular, square, triangular, etc.

The structural support apparatus 400 depicted in FIG. 4 may be distinguished from the structural support apparatus 100 in FIG. 1, for at least the fact that the structural support apparatus 400 includes a stiffener plate 404. The stiffener plate 404 may anchor the pair of straps together, and may be located between above the base portion 402. One benefit gained by including a stiffener plate 404 is that, upon filling in the hole with concrete, gravel, or another material, the stiffener plate 404 provides additional surface area over which the filler spreads so as to increase the force with which the apparatus is secured under the ground.

Another difference between the features in FIGS. 1 and 4 is that the base portion 402 is depicted as being much thicker than the base portion 110, shown in FIG. 1. As such, the base plate 402 includes a large surface area of threads with which the bar engages, thereby providing greater stability for the apparatus during installation.

Unlike the structural support apparatus 400, the height adjustment system of the embodiment in FIG. 5 is not located in the base portion 512. Instead, FIG. 5 shows a block strap connector 502, which may include an upper part 504 and a lower part 506. A bar 508 may be fixed in place in the lower or upper parts 504, 506, or it may be loosely threaded in either as well. The threaded hole 510 depicted in the upper part 504 accommodates the bar 508, such that the height of the structural support apparatus 500 may be easily adjusted by rotating the upper portion of the straps.

FIGS. 6A and 6B illustrate variations of how the structural support apparatus may be secured to the ground surface to avoid slipping, especially if an embodiment that adjust via rotation is used. Regardless, the stabilizing projections may be able to help stabilize any of the embodiments. For example, in FIG. 6A, a ground plate 600A is shown with stabilizing projections 602A extending from a bottom side of the ground plate 600A. Similarly, in FIG. 6B, the lower portion of a structural support apparatus 600B is shown with similar stabilizing projections 602B. The shape of the stabilizing projections 602A, 602B can vary greatly. For example, stabilizing projections may be a spike shape, a tooth shape, or a claw shape. Additionally, the position of the stabilizing projections 602A, 602B may be oriented toward a lateral direction that is opposite a tangential direction of the rotation used to raise a height of the apparatus so as to counteract a rotational force of raising the height of the structural support apparatus. Thus, the stabilizing projections may pierce the ground surface. Further, the stabilizing projections may extend in a direction transverse to a direction of extension of the base portion between the straps and extends away from the straps.

FIGS. 7A-11 depict various additional embodiments of a height adjustment system of a structural support apparatus. Note that only a portion of the respective structural support apparatuses are shown in FIGS. 7A-11.

FIG. 7A shows a portion of a structural support apparatus 700 that has a bar 702, which includes a plurality of through holes. The bar 702 may extend through the base portion of the structural support apparatus and the lift assist component, a pin 704, may be sized to fit in the holes in the bar 702. As such, the structural support apparatus 700 can be raised and lowered to a desired height by simply removing the pin 704, placing the structural support apparatus 700 at the desired height, and inserting the pin 704 into the hole in the bar located immediately beneath the base portion of the structural support apparatus 700. In this manner, the weight of the apparatus may rest on the pin 704 and hold the correct height. FIG. 7B shows a side view of the structural support apparatus depicted in FIG. 7A.

FIG. 8 depicts a portion of a structural support apparatus 800 with a bar 802. The structural support apparatus 800 may further include a lift assist component 804, which may be a compression sleeve 804 disposed within a hole in the base member. The height adjustment system functions via a compression fit of the sleeve 804 surrounding the bar 802. Thus, in the embodiment in FIG. 8, the height of the structural support apparatus 800 is adjusted by simply sliding the structural support apparatus 800 up or down along the bar 802 by forcing the bar 802 through the compression sleeve 804.

In an alternative embodiment shown in FIG. 9, the height adjustment system of the structural support apparatus 900 may include a bar 902 that may include notches or grooves and a lift assist component including a set screw 904 and a collar 906 in which the set screw may be inserted. The alternating short and long lines seen on the bar 902 (and similarly on the bar 1002) may represent either notches or grooves. The notches or grooves may be angled to a specific direction so as to be more effective for maintaining a specific desired height. The height of the structural support apparatus 900 may be adjusted by raising or lowering the apparatus 900 along the bar 902 to a desired height, and then sliding the collar 906 up to the base portion of the structural support apparatus 900, as depicted in FIG. 9. Then, the set screw 904 may be tightened into the collar 906 to have the set screw 906 tightly clamp the collar 906 against the bar 902 in compression. The set screw 904 may be either inserted into a notch or a groove (or an unaltered side wall) on the bar 902 through the collar 906, or it may clamp the collar 906 down around the bar 902.

In yet another alternative embodiment of a structural support apparatus 1000, FIG. 10 depicts a height adjustment system that includes a bar 1002, having grooves or notches, and a lift assist component, which is one or more spring-loaded, hinged wedge members 1004. As depicted in FIG. 10, the wedge members 1004 are angled from the base portion of the structural support apparatus 1000 so as to point downward against the notches or grooves in the bar 1002. More specifically, the hinged wedge members 1004 open downwardly toward a ground surface and are hinged so as to close against a side of the bar 1002 and engage the notches under a force of the weight of the apparatus 1000. In this manner, engagement between the wedge members 1004 and the bar 1002 make a height adjustment by allowing the wedge members 1004 to flex downwardly and loosely while raising the straps, and yet locking the wedge members 1004 in place against the bar 1002, which prevents the wedge members 1004 from flexing upwardly and prevents downward movement of the straps.

Though not explicitly shown, the wedge members 1004 may be spring-loaded by spring that extends from the base

portion of the structural support apparatus 1000 to a top side of the wedge member so as to create an upward force against the bar 1002.

The height adjustment system in the embodiment of the structural support apparatus 1100 in FIG. 11 is similar to the height adjustment system depicted in FIG. 7. However, in the embodiment depicted in FIG. 11, there are two bars 1102 (though only one may be needed), each of which has a plurality of through holes along the length of the bar 1102. The height adjustment system may further include a central stabilizing member 1104 that extends through the base portion 1108, and at least one pin rest (bracket) 1106, which may be attached to either one or both sides of the straps in the structural support apparatus 1100. The bars 1102 extend respectively through the pin rests 1106 on the outside of the straps of the structural support apparatus 1100. Furthermore, the bars 1102 may rest against or may be fixed in position to the ground plate 1110. Therefore, in order to adjust the height of the structural support apparatus 1100, the apparatus may be raised or lowered along a length of the bars 1102. Then, when located at the desired height, a pin 1112 may be inserted into the hole just beneath the pin rests 1106, so that the pin rests sit on the pin to prevent downward movement of the structural support apparatus 1100.

In an alternative embodiment, (not depicted) the height adjustment system of the structural support apparatus 1100 may function without the base portion 1108 or the central stabilizing member 1104. Thus, the structural support 1100 may be raised or lowered and supported only by the bars 1102 sliding in the pin rests 1106 and being fixed to the ground plate 1110.

#### Illustrative Embodiments of a Method of Installing a Structural Support Apparatus

In FIG. 12, a flowchart of a method of installing a support member 1200 is shown. In particular, a support member may be placed on a ground surface 1202. The support member may be any of the embodiments described above. The height of the support member is adjusted 1204 by engaging the lift assist component with the bar. This may be achieved using any of the methods above. A structural support member is secured to the straps 1206. Additionally, generally one of concrete or gravel is placed around the lower ends of the straps to fix the support member in place. In order to secure a structural support column to the straps, the support column is rested on the support column rest, and the support column is secured between the straps via fastening hardware inserted into holes in upper ends of the straps.

Another embodiment of a method of installing a structural support apparatus may include pouring a footing in a hole, and then bolting the base portion or ground plate of the structural support apparatus to the footing. The height may then be adjusted to set the apparatus to grade and the post or column may be fixed to the support apparatus. The footing may vary in size and the support apparatus may vary in height depending on the job. The apparatus may further have the ability to be locked to prevent turning, for example, if threaded, there may be a nut on the top and bottom.

In yet another embodiment, the apparatus may be used to set manufactured homes. For example, the support apparatus may be flipped upside down with no straps so that the height adjustment system is facing up. The height adjustment system may be welded or bolted to the metal frame of the manufactured home. The apparatus may also be bolted to a footing or wet set it in the ground.

#### CONCLUSION

Although several embodiments have been described in language specific to structural features and/or methodologi-

cal acts, it is to be understood that the claims are not necessarily limited to the specific features or acts described. Rather, the specific features and acts are disclosed as illustrative forms of implementing the claimed subject matter.

What is claimed is:

1. An apparatus, comprising:
  - a first strap including an upper end and a lower end;
  - a second strap disposed adjacent the first strap and including an upper end and a lower end, the upper and lower ends of the second strap corresponding in position with respect to the upper and lower ends of the first strap;
  - a base portion connecting the first and second straps between the respective lower ends of the first and second straps;
  - a height adjustment system including
    - at least one bar disposed so as to extend through the base portion into a space between the first and second straps, and
    - a lift assist component that engages with the bar such that, in an orientation where the first and second straps extend vertically with respect to a horizontal plane, a distance between the horizontal plane and the respective upper ends of the first and second straps is adjustable via engagement between the lift assist component and the bar; and
  - a connection member connecting the first strap and the second strap and spaced apart from the base portion so as to be between the respective upper ends and lower ends of the first strap and the second strap, the connection member being a support column rest,
    - wherein the first strap and the second strap include through holes extending through the respective upper ends of the first strap and the second strap above the connection member.
2. The apparatus according to claim 1, wherein the base portion includes a hole, a first end of the bar extending through the hole on a first side of the base portion that faces toward the space between the first strap and the second strap, and a second end of the bar extending through the hole on a second side of the base portion that faces opposite the first side of the base portion, and
  - wherein the height adjustment system further includes a ground plate attached to the second end of the bar, the ground plate extending in a plane transverse to a direction of extension of the bar.
3. The apparatus according to claim 1, wherein the bar is a threaded rod, and the lift assist component is a threaded surface correspondingly shaped to thread the rod therein,
  - wherein the base portion includes a hole, the threaded surface being in or adjacent to the hole so that the rod extends through the hole, and
  - wherein the distance between the horizontal plane and the respective upper ends of the first and second straps is adjustable via rotational engagement between the threaded surface and the rod.
4. The apparatus according to claim 3, wherein the base portion includes a plate, on opposite sides of which the respective lower ends of the first and second straps are attached, and
  - wherein the hole extends through the plate in a direction orthogonal to a plane of extension in which the plate extends.
5. The apparatus according to claim 3, wherein the base portion includes a parallelepiped, on opposite sides of which the respective lower ends of the first and second straps are attached, and

wherein the hole extends through the parallelepiped in a same direction as a direction of elongation of the first and second straps.

6. The apparatus according to claim 3, wherein the rotational engagement is achieved via rotation of the upper ends of the first and second straps about an axis of the rod.

7. The apparatus according to claim 1, wherein the through holes are configured to permit attachment of a structural support column between the first and second straps via hardware in the plurality of through holes.

8. An apparatus, comprising:
  - a pair of straps facing each other;
  - one or more connection members disposed between the straps and anchoring the straps at a fixed distance from each other to accommodate a structural support column therebetween, the one or more connection members including a support column rest and a base portion; and
  - a height adjustment system including
    - at least one bar disposed so as to extend through the base portion into a space between the straps and between the support column rest and the base portion, and
    - a lift assist component that engages with the bar such that, in an orientation where the straps extend vertically with respect to a horizontal plane, a distance between the horizontal plane and a top of the support column rest is adjustable via engagement between the lift assist component and the bar,

wherein the pair of straps include through holes extending through respective upper ends thereof at a position above the support column rest and on an end opposite the base portion, and

wherein the support column rest is spaced apart from the base portion by the space between the straps into which the at least one bar extends.

9. The apparatus according to claim 8, wherein the bar is a threaded rod, and

wherein the distance between the horizontal plane and the top of the support column rest is adjustable via rotation of upper portions of the straps about an axis of the rod.

10. The apparatus according to claim 8, wherein the one or more connection members further includes a stiffener plate, which connects the straps between the support column rest and lower portions of the straps, such that a space exists between the stiffener plate and the support column rest.

11. The apparatus according to claim 10, wherein the space is a first space, and

wherein the base portion connects the straps at a bottom end of the lower portions thereof, such that a second space exists between the stiffener plate and the base portion.

12. The apparatus according to claim 8, wherein the base portion includes at least one stabilizing projection for piercing a ground surface, the stabilizing projection extending in a direction transverse to a direction of extension of the base portion between the straps and extends away from the straps.

13. The apparatus according to claim 12, wherein the support column rest is adjustable via rotation of upper portions of the straps about an axis of the bar, and

wherein the at least one stabilizing projection extends transversely to a horizontal plane, and toward a lateral direction that is opposite a tangential direction of the rotation used to raise a height of the apparatus.

14. The apparatus according to claim 8, wherein the base portion includes a hole through which the bar extends, wherein the bar is a threaded rod, a first end of the rod extending through a first side of the base portion that

faces toward the space between the straps, and a second end of the rod extending through a second side of the base portion that faces opposite the first side of the base portion, and

wherein the height adjustment system further includes a ground plate attached to the second end of the rod, the ground plate extending in a plane transverse to a direction of extension of the rod.

15. The apparatus according to claim 14, wherein a width of the ground plate is wider than a corresponding width of the base portion so as to provide stability and help prevent the apparatus from tipping during a height adjustment.

16. The apparatus according to claim 14, wherein the ground plate includes at least one stabilizing projection for piercing a ground surface, the stabilizing projection extending in a direction transverse to a direction of extension of the ground plate and extends away from the ground plate.

17. The apparatus according to claim 8, wherein the at least one bar includes a plurality of holes extending through the bar in a direction transverse to a direction of extension of the bar, and

wherein the lift assist component is a pin that is correspondingly sized for insertion into the plurality of holes, such that the engagement between the lift assist component with the bar to make a height adjustment includes inserting the pin into a hole on the bar beneath the base portion after raising the straps of the apparatus to a desired height so that the base portion rests on a portion of the pin and is prevented from lowering against the bar.

18. The apparatus according to claim 8, wherein the at least one bar includes a plurality of holes extending through the bar in a direction transverse to a direction of extension of the bar, and

wherein the lift assist component is a pin that is correspondingly sized for insertion into the plurality of holes, such that the engagement between the lift assist component with the bar to make a height adjustment includes inserting the pin into a hole on the bar beneath a pin rest bracket, which retains the bar against a side of one of the

pair of straps, after raising the straps of the apparatus to a desired height so that the pin rest bracket rests on a portion of the pin and is prevented from lowering against the bar.

19. The apparatus according to claim 8, wherein the base portion includes a hole through which the bar extends, and wherein the lift assist component includes a compression sleeve disposed in or adjacent to the hole in the base portion so that the bar passes through the base portion under a force sufficient to overcome resistance created by the compression sleeve.

20. The apparatus according to claim 8, wherein the base portion includes a hole through which the bar extends, and wherein the lift assist component includes a set screw such that the engagement between the lift assist component with the bar to make a height adjustment includes tightening the set screw into the bar beneath a base portion, which is a connection member, after raising the straps of the apparatus to a desired height so that the base portion rests on a portion of the set screw and is prevented from lowering against the bar.

21. The apparatus according to claim 8, wherein the base portion includes a hole through which the bar extends, the bar having a plurality of notches disposed on an outside surface thereof, and

wherein the base portion further includes one or more spring-loaded, hinged wedge members, which open downwardly toward a ground surface and are hinged so as to close against a side of the bar and engage the notches under a force of a weight of the apparatus, whereby engagement between the lift assist component and the bar to make a height adjustment is achieved by allowing the wedge members to flex downwardly to raise the straps, while locking the wedge members in place against the bar which prevents the wedge members from flexing upwardly and prevents downward movement of the straps.

\* \* \* \* \*